

# INFORMATION

ADDRESS λ PHONE λ FAX λ MAP

## HOLLYWOOD

937 NORTH CITRUS AVE.  
HOLLYWOOD, CA. 90038

PHONE  
323.461.9900

FAX  
323.461.0100

EMERGENCY  
213.350.0050

## PARK CITY

P.O. BOX 2850  
430 CENTENNIAL CIR.  
PARK CITY, UTAH 84060

PHONE  
435.649.1030

FAX  
435.649.2437

Dear Friends and Colleagues,

Rocky Mountain Motion Pictures has many exciting things to tell you about in the year 2000! Our continued growth and support by directors, cameramen, and major studios has enabled us to provide complete first and second unit camera packages on studio feature films, most recently: "Austin Powers The Spy Who Shagged Me", "Bowfinger", "Stuart Little", "Nurse Betty", as well as commercials and series television.

As of February 2000 we will be in our new Camera Rental/Stage complex in Hollywood, across from Pascal Lighting and three blocks east of Warner Hollywood Studios. The new facility will offer some "camera assistant friendly" amenities including:

Camera Asst. Office with phone/fax/copier	
Private Parking	Insert/Test/Stage
Machine Shop	Easy load in/out

We hope this new rental catalog concept, designed with a flow chart style by Nuprint Comics, will make your equipment choices easier. Also, please take a minute to glance over the "one sheet" camera equipment charts on the last pages of the catalog which have an overview of our entire inventory on one page. Simply circle the needed items and fax it to our rental department for an exact quote.

We greatly appreciate the technical help and support from Moviecama's Gabriel Bauer and Arriflex Vienna's Walter Trauninger who have kept us on the cutting edge of motion picture technology. We will continue to provide you with the latest Moviecama and Arriflex innovations as well as other new items including:

Cooke S4 Primes	Arri Ultra Primes
Revolution Lens System	Hawk 150-450mm T.2.8

Lastly, in June, ~~Rock Stock~~ our Park City based stock footage company will open a branch in our Hollywood office. We are always looking for new footage and hope many of you will be interested in participating in the expansion of our stock footage library.

If you have not already used our cameras, please consider us on your next project or just come by and say hello!

The Rocky Mountain Team

# ROCKY MOUNTAIN

## CAMERAS

**MOVIECAM  
COMPACT & SL**

MAGS  
1000FT. 400FT.  
STEADIMAGS. SL400FT

**ARRI 435ES w/ IVS**

MAGS  
1000FT. 400FT.  
STEADIMAGS

**ARRI III & ARRI  
IIC**

MAGS  
1000FT. 400FT.

## LENSES

**PRIME**

ARRI  
ULTRA PRIMES  
10.14.16.20.24.  
28.32.40.50.  
85.100.135  
T 1.9

COOKE  
S4 PRIMES  
14.18.25.32.  
40.50.75.100  
T 2

ZEISS  
SPEED  
18.25.35.  
50.85  
T 1.3

ZEISS  
STANDARD  
16.24.32.50.  
85.T 2.1

ZEISS  
PRIMES  
28.40.65.

**ZOOM**

COOKE  
18-100  
T3

ANGENIEUX  
25-250 HR  
T 3.5

16MM  
ZEISS  
10-100  
T 2

16 MM  
CANON  
8-64  
T 2.4

HAWK  
RODENSTOCK  
150-450MM  
T 2.8

**SPECIAL**

NIKON  
8MM  
2.8  
ZEISS  
14MM  
T2.1

ZEISS  
10MM  
T2.1

ZEISS  
MACROS  
16.24.32.50

ZEISS  
100 MM  
MACRO

ZEISS  
200 MM  
MACRO

REVOLUTION  
LENS SYSTEM  
9.8.12.16.20.  
24.32.40.60  
MINI PL OR PL

## CAMERA AKS

**ARRI  
MATTEBOX**

CLIP-ON  
LMB4 6X6 LMB5 4X5.6

STUDIO  
MB14 6X6 MB18 4X5.6

**FOLLOW FOCUS**

ARRI  
FF3. FF4. & LTWT

WILLYTECH  
STUDIO & H.H.

PRESTON FIZ

## HEADS

ARRI II GEAR  
HEAD

OCONNOR  
2575

CARTONI DUTCH  
HEAD

SWING HEAD

WEAVER  
STEADMAN

# 35mm CAMERAS

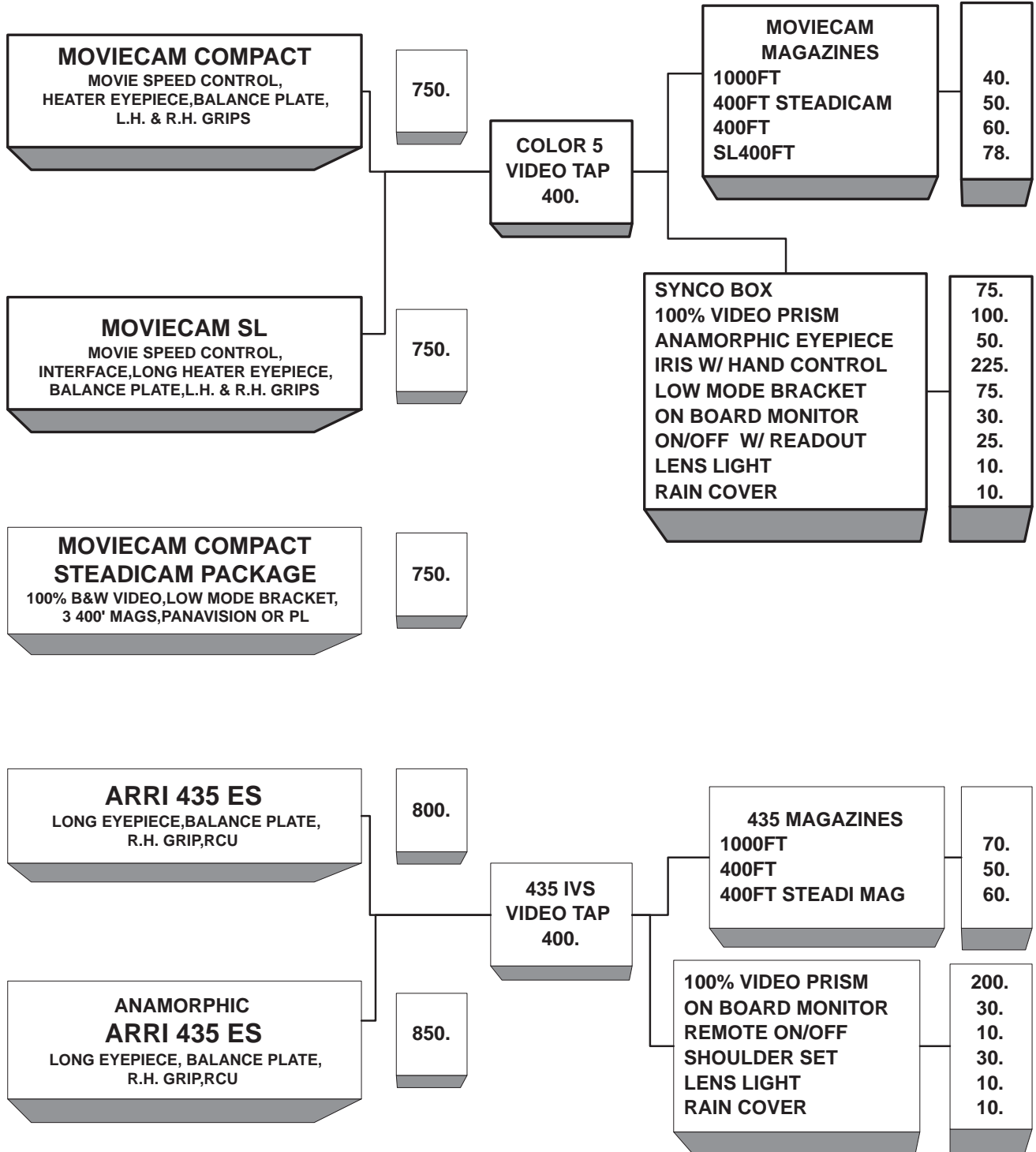

## 35mm CAMERAS

CONTINUED

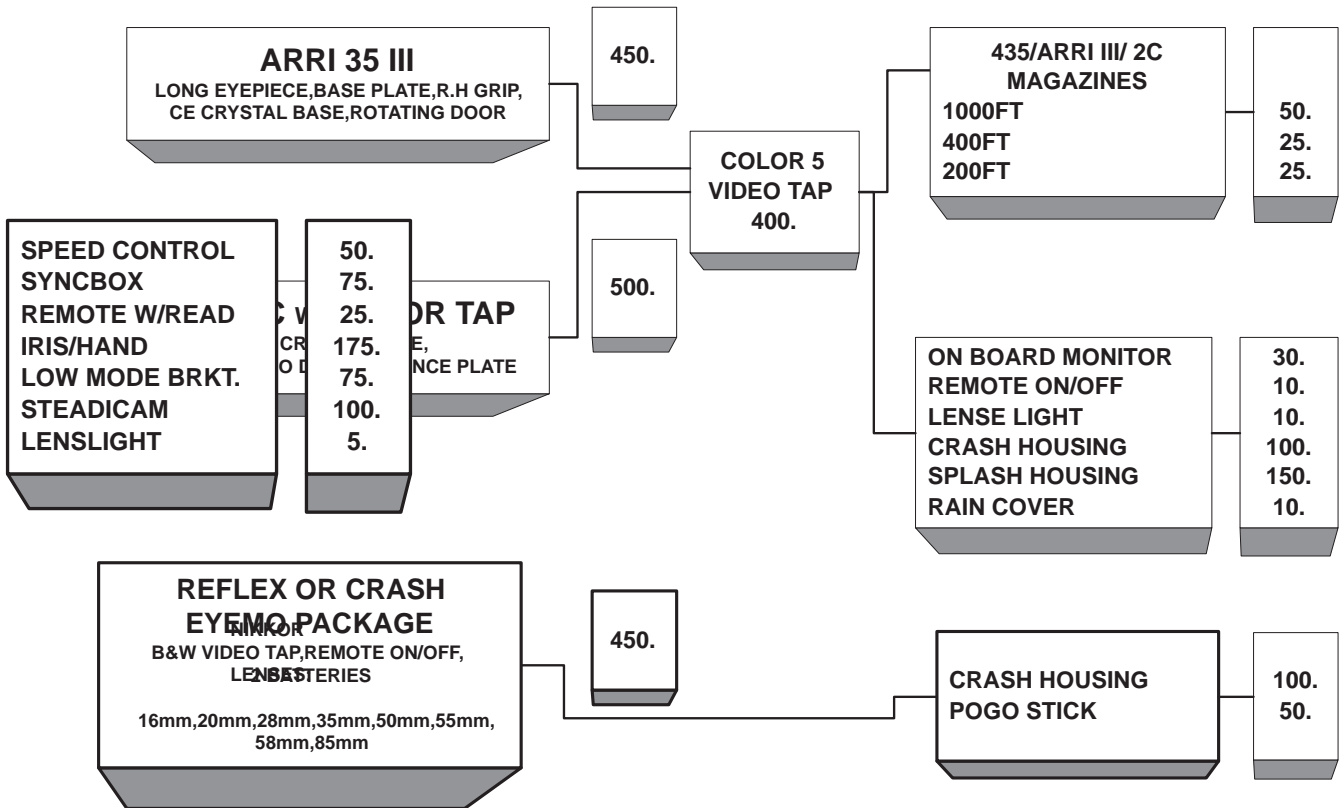

## 16mm CAMERAS

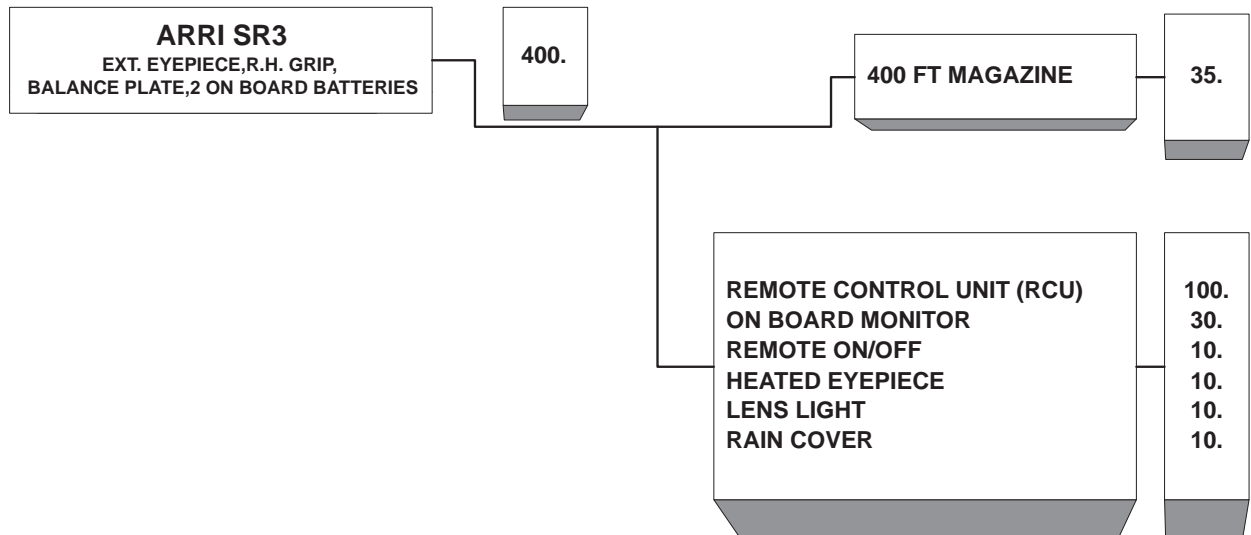

# 35mm PRIMES

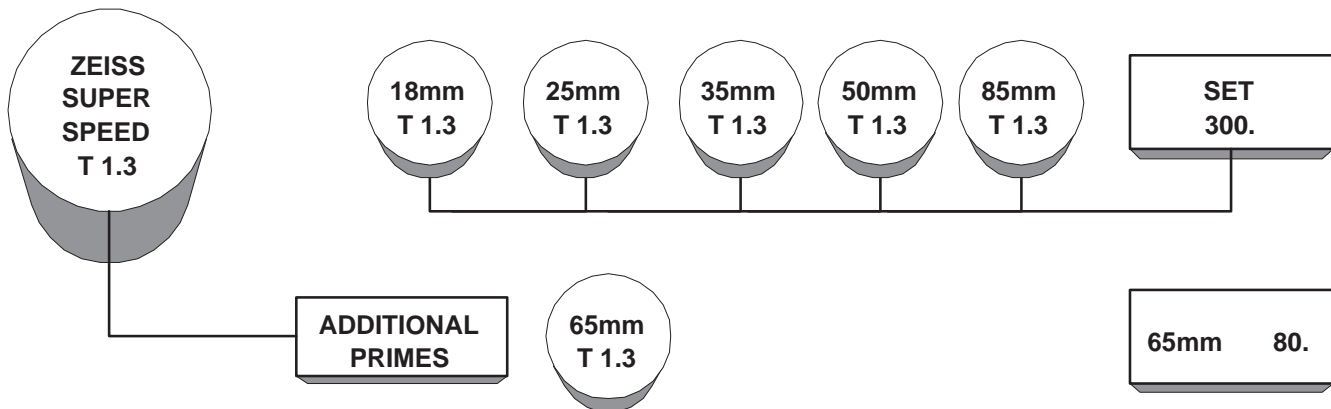
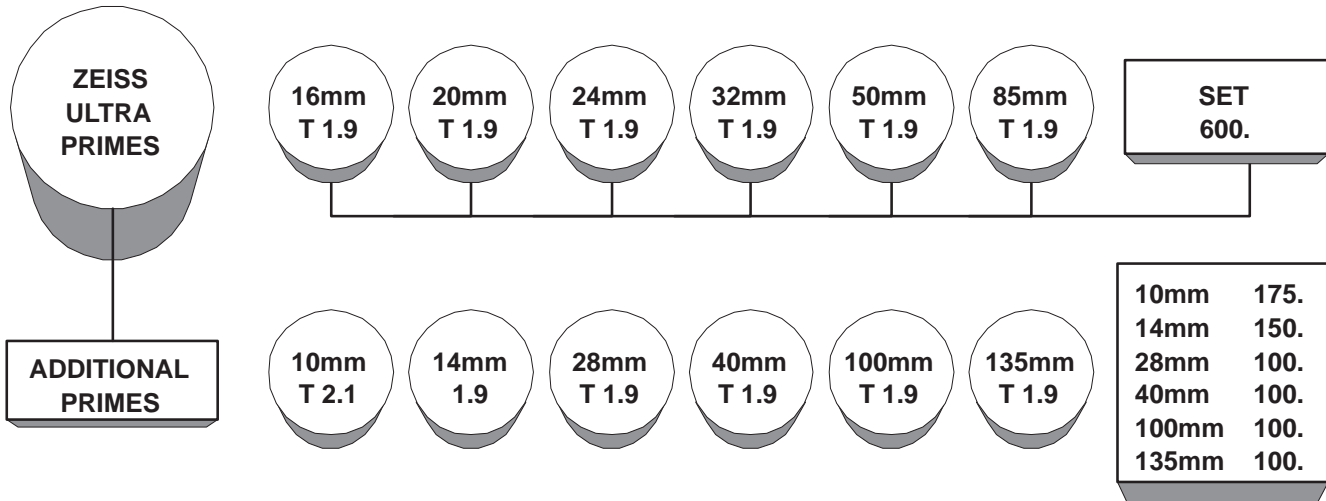
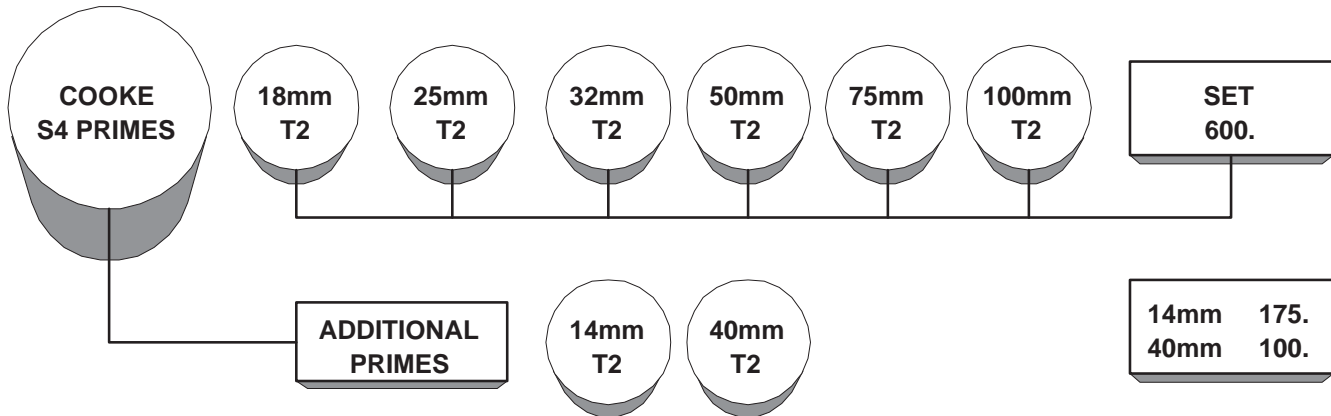

# 35mm PRIMES

CONTINUED

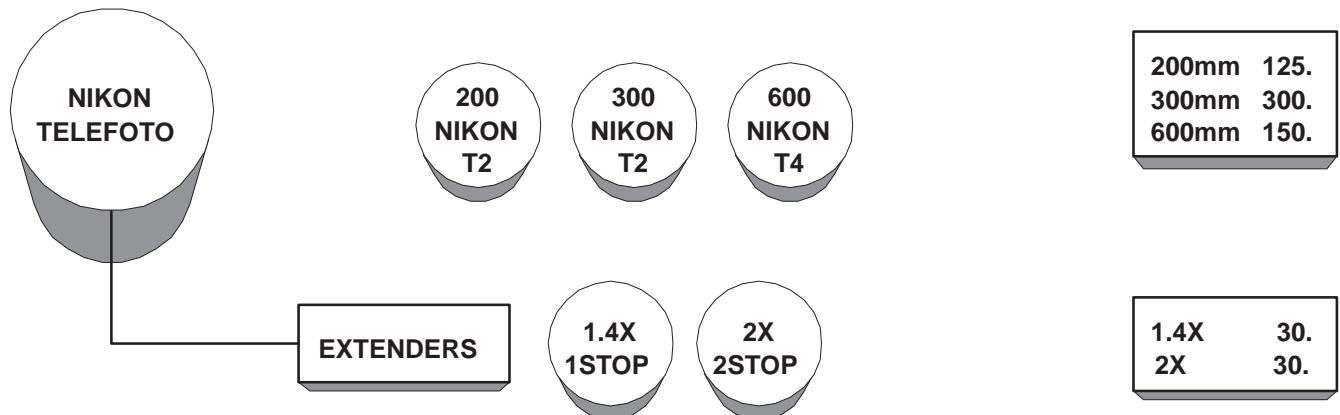
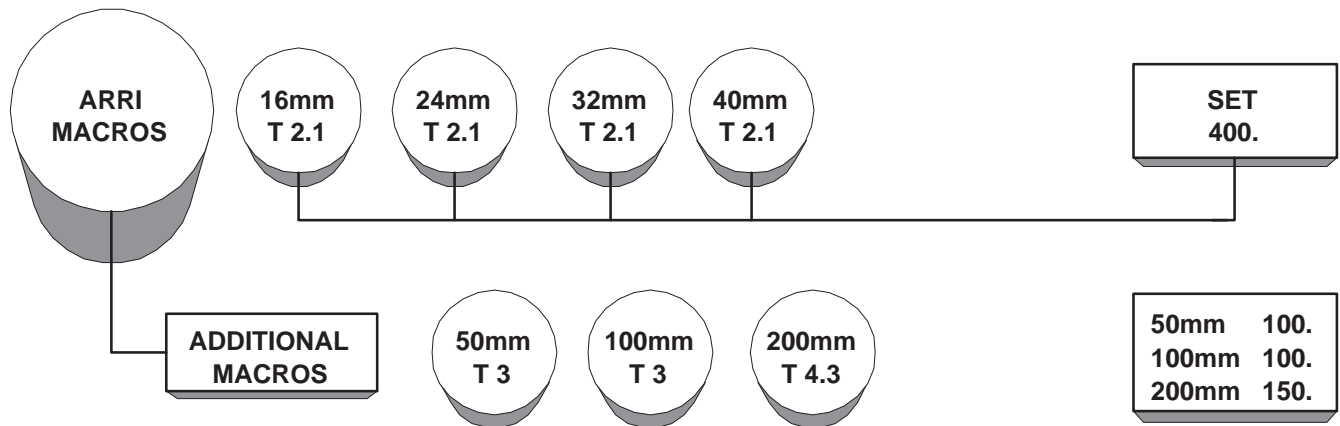
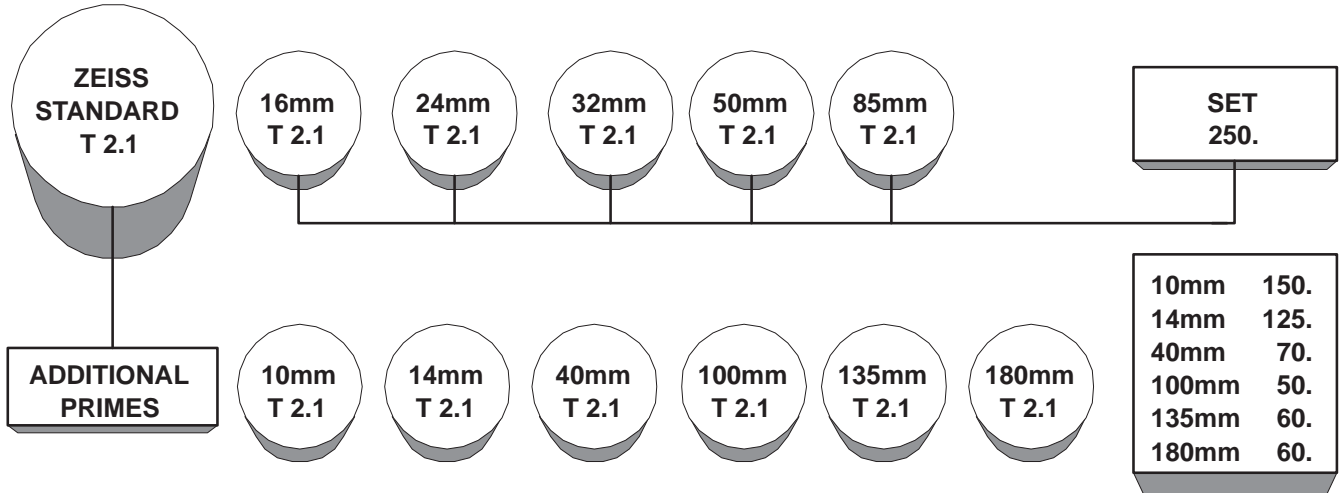

**35mm  
ZOOM LENSES**

**HAWK-RODENSTOCK  
150-450MM T 2.8**

150-450 mm 495.

**INCLUDES ZOOM  
CONTROL**

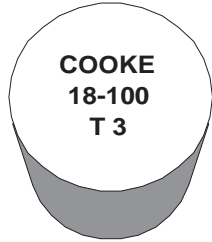

18-100mm 320.  
17-102mm 320.  
25-250mm 320.

**INCLUDES ZOOM  
CONTROL**

**KISH  
DIRECTOR'S  
FINDER**

50.

**16mm  
LENSES**

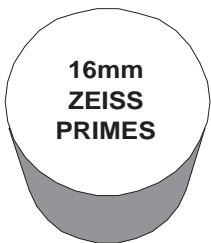

**SET  
300.**

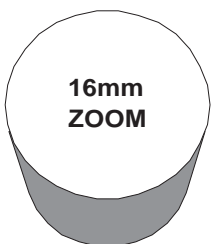

10-100mm 150.  
8-64mm 220.  
11-165mm 225.

**INCLUDES  
ZOOM  
CONTROL**

# SPECIAL LENSES

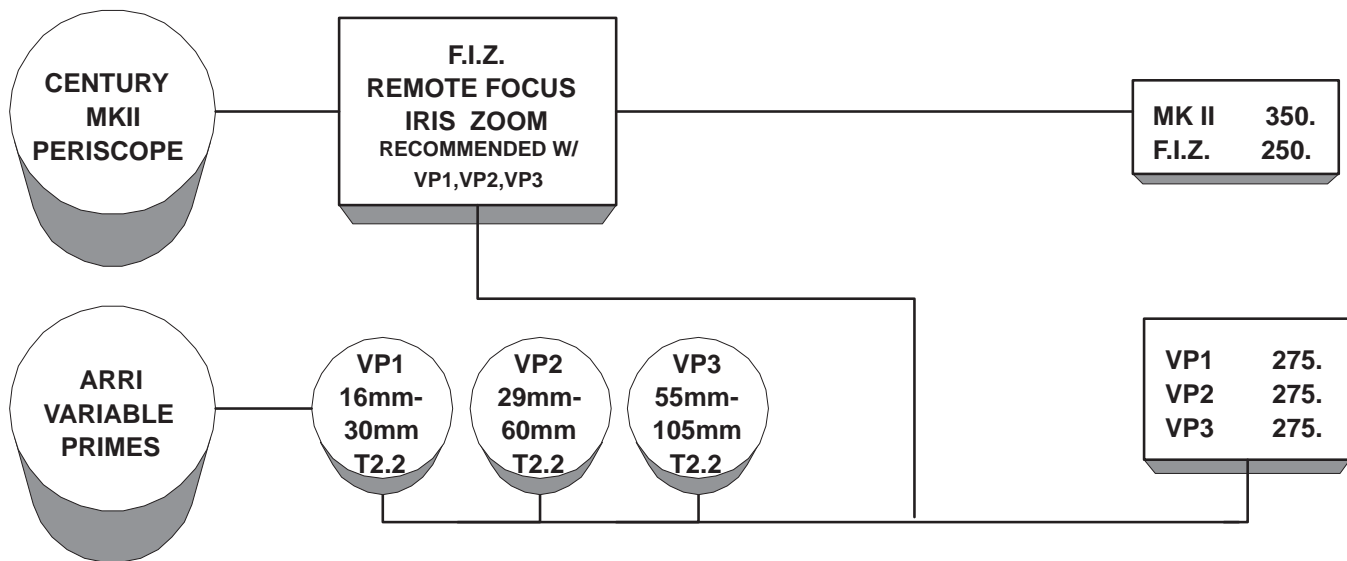
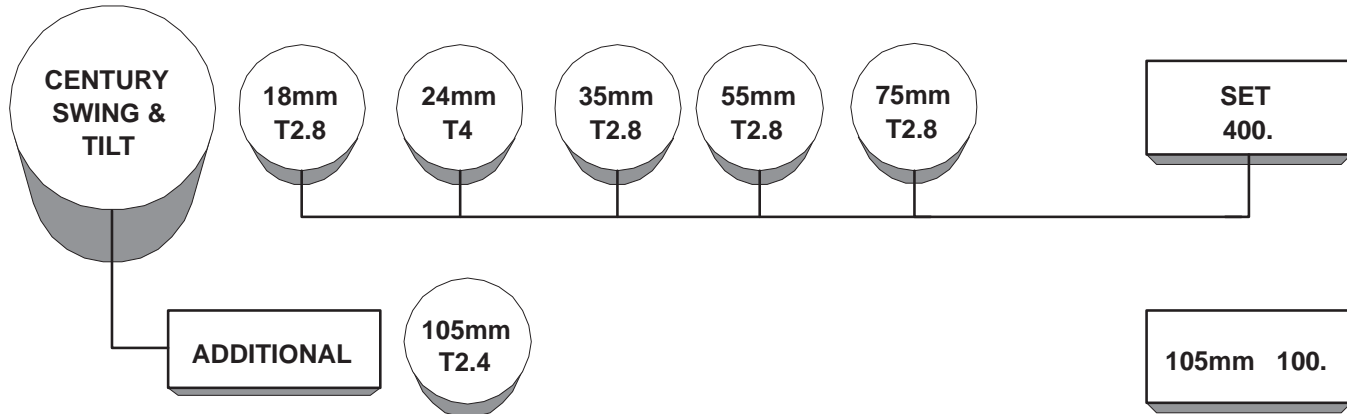
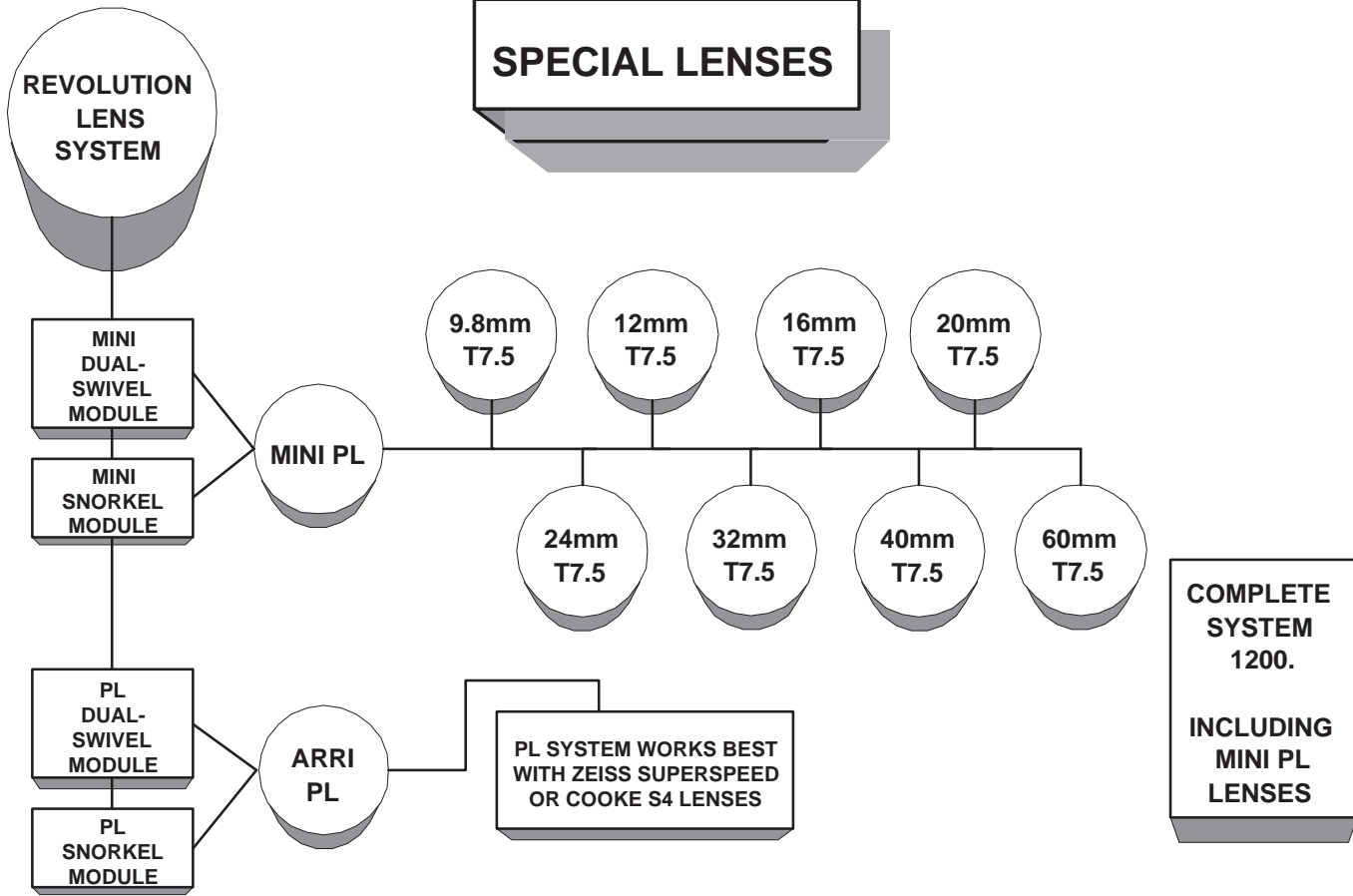

**35/16mm CAMERA  
ACCESSORIES**

**ARRI CLIP-ON  
MATTEBOX**

**LMB4 6x6**

**LMB5 4x5.6**  
INCLUDES  
HARD MATTES & EYEBROW

<b>LMB4</b>	<b>30.</b>
<b>LMB</b>	<b>35.</b>

**ARRI STUDIO  
MATTEBOX**  
INCLUDES  
EYEBROW & HARDMATTE SET

**MB14 6x6**

**MB18 4x5.6**

<b>MB14</b>	<b>45.</b>
<b>MB18</b>	<b>45.</b>

**FOLLOW FOCUS**

**ARRI FF3**

**ARRI FF4**

**ARRI  
HAND HELD**

**WILLYTECH  
STUDIO/ HAND HELD  
PACKAGE**

<b>FF3</b>	<b>35.</b>
<b>FF4</b>	<b>45.</b>
<b>ARRI H.H.</b>	<b>30.</b>
<b>WILLYTECH</b>	<b>60.</b>

**MISCELLANEOUS**

**PRESTON FIZ  
FOCUS . IRIS . ZOOM**

**DIGITAL ZOOM CONTROL,  
WIRELESS TRANS / RECEIVER ,  
3 MOTORS**

**PACKAGE  
250.**

**PRESTON  
DIGITAL ZOOM**

**DIGITAL CONTROLLER,  
DIGITAL MOTOR**

**PACKAGE  
55.**

**CINEMATOGRAPHY  
ELECTRONICS**

**FILM/VIDEO  
SYNCHRONIZER**

**LASER POINTER**

**SYNCHRONIZER 150.  
LASER POINTER 150.**

**NORRIS ARRI III  
TIMELAPSE  
INTERVALOMETER**

**PACKAGE  
150.**

## HEADS

ARRI II GEAR HEAD	200.	HIGH HAT/LOW HAT	10. EACH
OCONNOR 2575	80.	SACHTLER 9+9 SACHTLER STUDIO 65	85. 80.
CARTONI DUTCH HEAD	80.	MISC. SUPPORT	
SWING HEAD	100.	ROCK & ROLL HANDLE RONFORD PLATE GEARED TILT PLATE ROCKER PLATE	10. 12. 25. 35.

RONFORD STICKS PACKAGE		STANDARD LEGS BABY LEGS SPREADER HIGH HAT	SET 55.
WEAVER STEADMAN		WEAVER STEADMAN 2 - AXIS	100.
		WEAVER STEADMAN 3RD AXIS	100.

## BATTERIES

14/28 VOLT BLOCK FOR HIGH SPEED 435	40.	12/24 BELT	30.
12/24 SUPER BLOCK	35.	12 VOLT CINE 60 LIGHT WEIGHT	15.

**FILTERS**  
TIFFEN, SCHNEIDER, HARRISON

RMMP CARRIES A WIDE RANGE OF COLOR, GRADUATED & EFFECTS FILTERS IN THE FOLLOWING SIZES

6X6

4X5.6

138mm

SER. 9

40.5

6X6	10.
4X5	10.
138	10.
SER. 9	5.
40.5	4.

**VIDEO**

**TRANSMITTERS**

MODULUS 2000

MODULUS 3000

2000	50.
3000	50.

**MONITORS**

SONY 3" COLOR ON-BOARD

TRANSVIDEO 5" ON-BOARD

SONY 8" COLOR

SONY 20" COLOR

3"	30.
5"	30.
8"	50.
20"	85.

**RECORDERS**

SONY VIDEO 8 WALKMAN

100.
------

**FINDERS**

VIDEO DIRECTOR'S VIEW FINDER

175.
------